

# 62xx-OB Foot Bellows

# herga

Technology Ltd

- 6289 compact, robust construction with colour options available upon request
- 6254 aluminium construction for harsh environments with strong conduit tubing
- 6210 tough reinforced plastic construction with light, easy operation



## Reference Dimensions

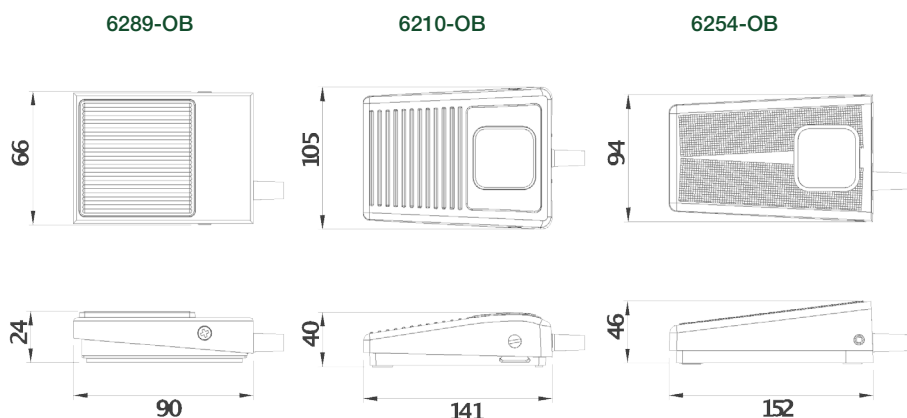

## General specifications

Standards/approvals	N/A	Operating temperature range	-10°C to +40°C
Degree of protection	EN 60529 IPX2	Body material	See table below
Connection method	See table below	Weight	See table below
Electrical rating	N/A	Additional information	
Contact configuration	N/A		
Pressure range	Works with 6871, 6872, 6773, 6753, 6891, 6893, 6861, 6862, 6863, 6864, 6869 – dependent on tube length		

## 62xx-OB - Range options and specifications

Model no	6289-OB	6210-OB	6254-OB
Weight approx.	0.25Kg	0.2Kg	0.475Kg
Optional black guard	available upon request		
Air connection	complete with 2m tube (black) with 3mm I/D	complete with 2m tube (black) with 3mm I/D	complete with 2m tube (black) with 3mm I/D & armor flex covering
Alternative air connection	see note below		
Material: body/base	16 SWG mild steel, powder coat grey Hammertone	thermoplastic	die-cast aluminum, powder coat black
3mm I/D & 6mm O/D, which are available in different lengths			

## Accessories

Part Number	Description
6202-0001	Single Black RAL 9005 guard
6202-0002	Single Grey RAL 7035 guard
6202-0003	Twin Grey RAL 7035 guard

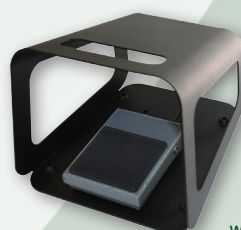

With 6202 Guard