

EM-143s DC-MOTOR SERVOCONTROLLER 12-32V 4A 4-QUAD

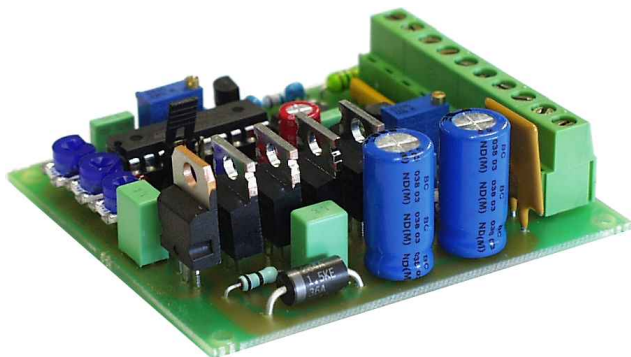

FEATURES:

- Small size
- Positioning precision 1/400
- Four drive quadrants
- High efficiency >92%
- For motors 5-100W
- Rail mounting base fittable
- Adjustable current limit
- Adjustable output current
- Adjustable positioning window
- Settable maximum speed

EM-143s is a motor controller for permanent magnet DC-motors. The unit is primarily designed for positioning usage, where position information is derived from potentiometer or as voltage, for example spindlemotors equipped with potentiometers.

The unit is so called four quadrant controller, in other words it drives and brakes in both directions. The braking is regenerative by nature as it feeds braking energy back to power source. If the power source is not a battery the unit will feed braking energy to motors internal resistance.

EM-143s has a window comparator, which measures the difference between feedback and reference value and uses this to control the motor. The unit has an adjustable positioning window, that specifies the level of difference to occur for correction to take place, in other words the precision of positioning. Range and zero -trims can be used to match the reference value with feedback value. Using the start level adjustment the minimum motor voltage can be suited for the application. Too low start level will result in motor warming and increased current consumption as a consequence of the motor not being able to perform small corrections due to lack of power. Too high start level will cause too rapid corrections or oscillation.

Motor current can be limited using motor current adjustment. It is possible to switch current limit into so called trip mode in which current limitation will switch off drive. If the current limit has been exceeded for one second, the unit won't be active until driven into opposite direction.

The power stage is protected against voltage peaks, overload and momentary shortcut. Reversed polarity connection should be avoided even though the unit is equipped with self recovery fuse.

TECHNICAL DATA

Supply voltage	12-32Vdc
Idle current	< 30mA
Fuse	4A self recovery
Load capacity	4A continuous 8A mom. (8s/30s) 14A mom. (2s/30s)
Current limit	1-14A
Operating freq.	approx. 22kHz
Control voltage	0-5...0-10V
Control potentiometer	1kohm...10kohm
"stop" control	4-30V "stop" <1V or open "drive"
Trip-indication output	NPN -open coll. 30V / 100mA
Input imp.	pins 6 and 9 = 50kohm pin 8 = 35kohm
Efficiency	>92%
Operating temp.	-10...50°C
Dimensions	(72 x 65 x 25) mm
Weight	approx. 80g

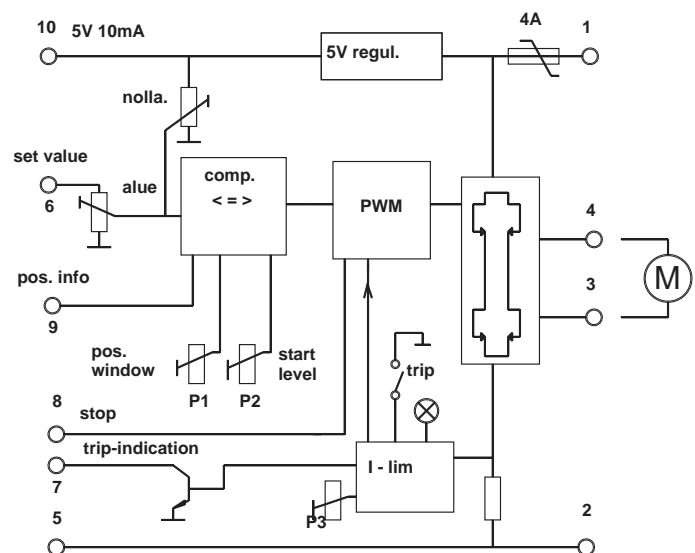

EM-143s USAGE

IMPORTANT !!

Supply voltage filtered (<20% ripple)
12-32VDC.

!! Check the polarity before connecting.

ADJUSTMENTS

Recommended start values in brackets.

START LEVEL (25%)

Adjustment sets motor start level.
Start level should be set so that motor always starts reliably but not too rapidly.

CURRENT LIMIT (= motor nominal current)

Set max. motor current (moment).
A red led indicates the activity of current limit.
At first it's recommended to set current limit low and increase the current to suitable level when the application seems to work.

POSITIONING WINDOW (2%)

Sets so called positioning window dimension.
Suitable value depends on the mechanics of the application. First set to the maximum, then decrease until application starts twitching, then set backwards until twitching ends. START LEVEL and WINDOW adjustment affect each other a little. To obtain best possible precision and positioning window start level must be precisely convenient.

RANGE AND ZERO

Use these adjustments to match reference and feedback values. For example, when using 100mm spindlemotor with only 70mm needed. Range adjustment is used to set frequency and zero for position, for example center. NOTICE that range adjustment also affects zero. Zero doesn't affect range. If these adjustments are inadequate external series resistors can be added to feedback potentiometer.

RANGE RESISTANCE (2.2k) (maximum speed)

Resistors are used to optimize the operation in specific voltage range.

- 1.8k 28V application
- 2.2k 24V application
- 3.3k 18V application
- 4.7k 12V application

EXAMPLE 1

Basic application where both set value and position value is derived from potentiometer.

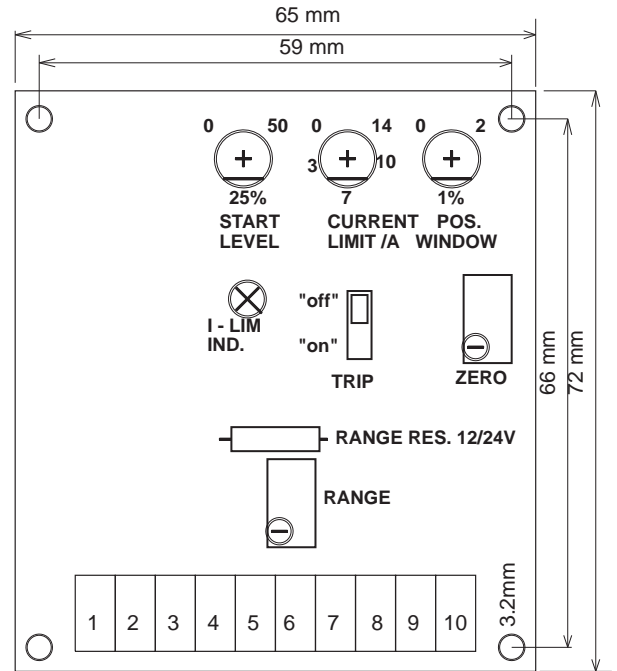
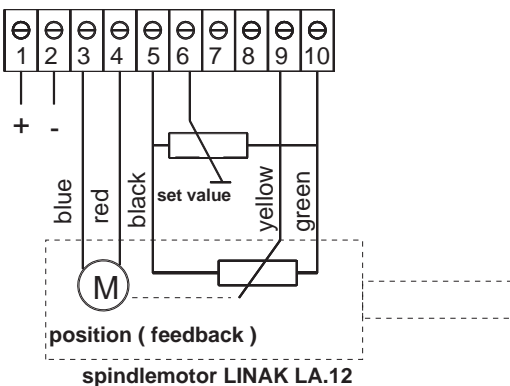

TERMINALS

- | | |
|--------------------------|---------------------------|
| 1. Supply voltage 12-32V | 5. Signal gnd (0V) |
| 2. Supply voltage 0V | 6. Set value in |
| 3. Motor out - | 7. Trip indication 100mA |
| 4. Motor out + | 8. Stop |
| | 9. Position feedback in |
| | 10. 5V 10mA reference out |

INTRODUCTION

Connect the application, adjust set value to approximate center. Switch on, application should seek its way to a certain point. Change the set value and position should change accordingly, if the application runs from one end to the other exchange motor leads with each other (3 and 4). Adjust the precision and dynamic to suit your application as described before.

EXAMPLE 2

In this application set value is given in voltage, and position from potentiometer.

