

EM-314 STEPPER MOTOR DRIVER 6A 12-24V microstepping and pre-settable function inputs

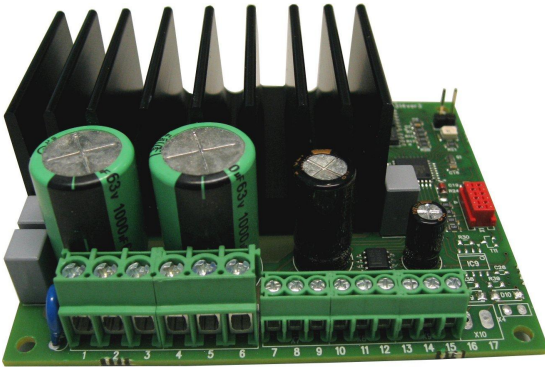

FEATURES

- Bipolar chopper
- 1, 1/2, 1/4.....1/64 steps
- Four preset function inputs
- PNP or TTL control
- Quiet run current control
- Acceleration / deceleration ramps
- DIN-rail base mountable

EM-314 is a bipolar-chopper type microstepping steppermotor controller. The bipolar operation principle suits most stepper motors and provides the best torque. The microstepping function also enables great performance at low rpm. The stepping and current regulation has been synchronized, giving a smooth and quiet operation. There are 7 different stepping options to choose from, ranging from full- to 1/64-step operation. This provides various possibilities for different speed applications.

The controller has its own auxiliary oscillator, which can be used for pre-set speed driving. The pre-set speeds can be activated by using 4 digital function inputs. The oscillator features an acceleration ramp function, which allows frequencies to be altered flexibly. The motor will also start up reliably even to higher frequencies and it is possible to shift to the desired velocity with out pace drop. The auxiliary oscillator incorporates an indexing part, which offers the possibility of running pre-settable operational sequences. These sequences can be activated with the 4 digital inputs. The sequence is a movement with selected speed, direction and distance (as steps). All the inputs are activated with positive logic commands. So the commands and functions are activated by connecting the input to a positive voltage. Control can also be done with TTL-logic level commands.

All of the controller settings are made digitally, using the separate setting device, EM-236 Interface Unit. With this device the settings are easily copied to an other or even to multiple controllers.

Operating voltage	12-35Vdc
Idle current	n. 20mA
Current settings	0.1 -6A (step 0.1A)
Auxiliary oscillator	50-10000Hz
Frequency accuracy	typ. 0.5%
Ramp adjust	0.1-5s (0 to 10000Hz)
Control level	"on" when Uin 4 -30V "off" when Uin 0-1V or open
Max. step freq.	15kHz
Operating temp.	0-50 °C
Dimensions	87x72.5x25mm
Weight	100g

CONTROL INPUT CONFIGURATION

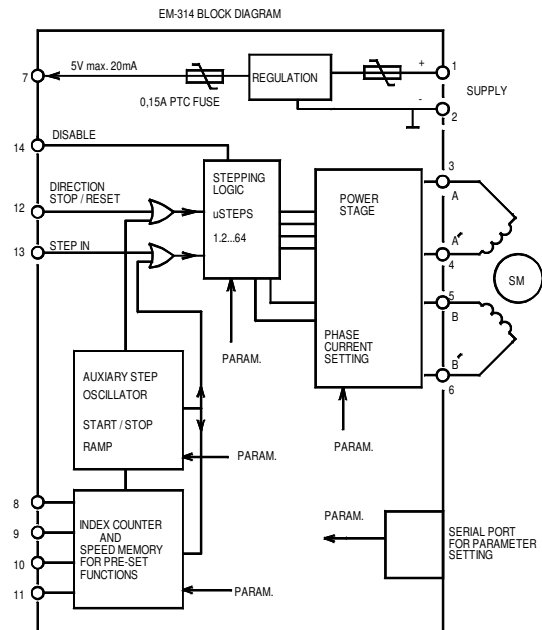
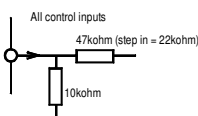

CONNECTIONS

Operating voltage 12-35Vdc, ripple smaller than 20%. The card has no internal fuse. The use of an external fuse is recommended. Incorrect supply polarity can damage the controller. All control inputs work with positive control 4-30V. Inputs can be controlled with PLC or TTL signals. 5V auxiliary output (terminal 7) can source max. 20mA.

CONTROL -inputs

STEP IN is the input for stepping pulses. One steps is done with the positive edge of the input pulse.
 DIR/STOP/RESET input is normally used to choose the rotational direction. If preset functions are used (terminal 8 to 11) this input can act as a stop input, and if preset sequence is used it will also reset the sequence counter. This input is triggered with up going pulse edge.
 DISABLE will shut down power stage and hold it disabled, this input has the highest priority. But it will not reset a sequence. So it is recommended to stop and reset functions before releasing disable to avoid any possible uncontrolled startup.
 PRESET IN 1-4 are presettable function inputs. These are used to activate chosen preset function. Function parameters include speed, direction, and distance in steps.
 If stepping distance is chosen to be zero, the drive will be continued as long as input is selected or STOP is activated. In other words the function works as preset speed driving.

PARAMETER SETTING

The card settings are made with a EM-236 Interface Unit or Ementool Lite PC soft-ware and EM-268 USB-dongle. EM-236 is connected to a red connector on the card. At first it will display the cards type and program version. Answering yes for LOAD and EDIT alternative the cards parameters are retrieved and displayed as a list that can be browsed with the arrow keys. Adjustment is done with +/- keys. The adjusted parameters are saved by pressing the SAVE key for about 2 seconds. After this, a notification will appear that that the new values has been SEND and SAVED. By choosing the MONITOR function, you can monitor the cards operation.

Status LED codes

continuous - power on
 disable input on - slow blinking
 temp. limit disable - fast blinking

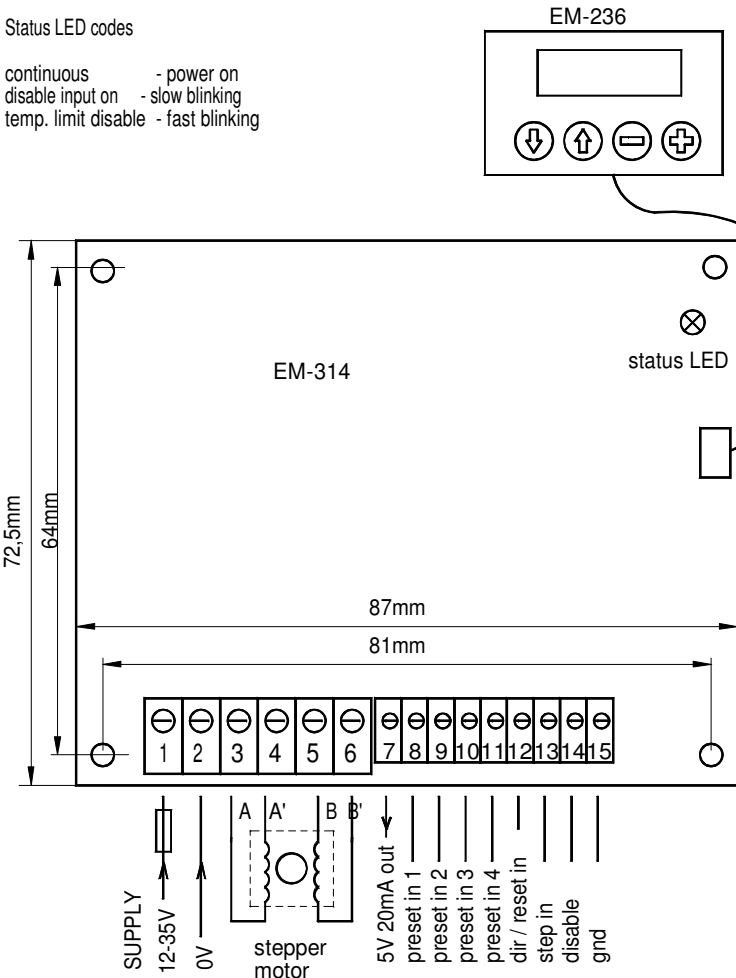

PARAMETER EFFECT

1. The stepping mode determines how much motor moves when card receives a step pulse. The most precise results are achieved with so called micro-stepping (partial step) setting and the highest possible resolution is 1/64-motor step against one incoming step pulse.
2. Ramp setting is common for acceleration- and deceleration. Ramp is in use with preset functions.
3. The current drop function limits the current to the set percentage during the rest-stage. This reduces the amount of the heat that motor has to dissipate. Notice. Lower values than 100% can reduce precision in micro-stepping driving.
4. Phase current limiting during the drive.
5. and 6. are not in use.
- 7.-22. These are to determine preset functions which are activated with PRESET IN # inputs. There are four preset functions available to be determined.
- 7.-10. Parameters to select the preset direction.
- 11.-14. Parameters to set the stepping frequency = speed
- 15.-22. Parameters for stepping amount = distance.

For example: Par.15 set to 393 and Par.16 set to 41 will result in 41393 steps total when terminal 8 (preset in 1) is activated.

Notice.
 The movement is in ratio to the used stepping mode. With 1/64 mode the movement is smallest, that is: $41393/64 = 646 + 49/64$ full steps

MONITORABLE VALUES

1. last activated preset function
2. sequence step down counter to zero
3. Step counter. Reset with a new sequence.

PARAMETERS of EM-314 prog 1.2 default values in brackets.

1. Stepping mode (0-6) [2]
 - 0 = full step
 - 1 = half step
 - 2 = quarter step
 - 3 = 1/8 step
 - 4 = 1/16 step
 - 5 = 1/32 step
 - 6 = 1/64 step
2. Ramp time 0.1-5s (1-50) [10]
3. Current 1s after stop (1-4) [4]
 - 1. 100% (= normal)
 - 2. 50% (reduced)
 - 3. 25% (reduced)
 - 4. 0% (current disabled)
4. Phase current 0.1-6A (1-60) [10]
5. not in use (0-1)
6. not in use (0-1)

- Preset run directions
7. preset 1. 0=fwd 1=rev [0]
 8. preset 2. 0=fwd 1=rev [1]
 9. preset 3. 0=fwd 1=rev [0]
 10. preset 4. 0=fwd 1=rev [1]

- Preset run frequencies
11. preset 1. 50-10000Hz (5-1000) [30]
 12. preset 2. 50-10000Hz (5-1000) [30]
 13. preset 3. 50-10000Hz (5-1000) [100]
 14. preset 4. 50-10000Hz (5-1000) [100]

- Index run counting values 0-1000000 step
 Setting 0= continuous run
15. preset 1. 0-999 (0-999) [0]
 16. preset 1. 0-1000 x 10³ (0-1000) [0]
 17. preset 2. 0-999 (0-999) [0]
 18. preset 2. 0-1000 x 10³ (0-1000) [0]
 19. preset 3. 0-999 (0-999) [0]
 20. preset 3. 0-1000 x 10³ (0-1000) [0]
 21. preset 4. 0-999 (0-999) [0]
 22. preset 4. 0-1000 x 10³ (0-1000) [0]

23. min start freq. 50-10000Hz (5-1000) [10]