

# 60HS

# HYBRID STEPPING MOTOR

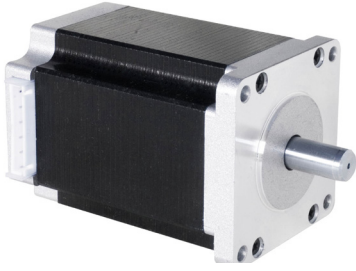

## General Specifications

Step Accuracy	± 5%
Temperature Rise	80 °C Max
Insulation Resistance	100MΩ Min.500VC DC
Ambient Temperature Range	-20°C~+50°C
Dielectric Strength	500VAC 1 minute
Max Radial Force	75N (20mm from front flange)
Max Axial Force	15N

## Technical Specifications

Model	Step Angle (°/Step)	Lead Wire (NO.)	Voltage (V)	Current (A/Phase)	Resistance (Ω/Phase)	Inductance (mH/Phase)	Holding Torque (Kg.cm)	Motor Height L (mm)	Motor Weight (Kg)
60HS63-1506-01	1.8	6	14.7	1.5	9.8	10.6	14	63	1.0
60HS67-1804-003A		4	4.68	1.8	2.6	7.8	16	67	1.1
60HS67-2204-001		4	3.96	2.2	1.8	5.0	16	67	1.1
60HS87-3504-001		4	4.0	3.5	1.15	4.5	27	87	1.4
60HS87-3008-003		8	3.9	3.0	1.3	3.2	21	87	1.4
60HS101-3008-001		8	6.0	3.0	2.0	4.0	25	101	1.6
60HS101-4204-002		4	4.2	4.2	1.0	4.0	33	101	1.6

\* Products can be customized by special request.

## Wiring Diagram

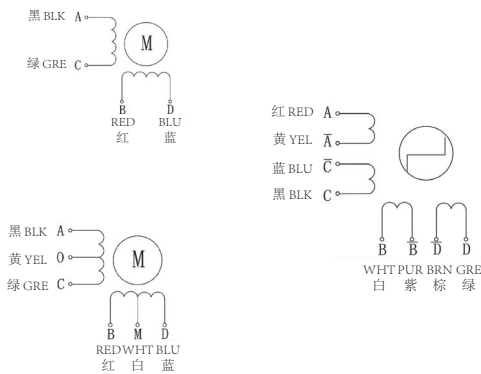

## Mechanical Dimension

