

UB/UBD T6 Series Motor Gear Units

Available in AC and DC versions

Output Torque: Upto 8Nm depending on speed and motor size

Speed range: 2.4 - 425 rpm

Our most versatile offering, the UBT6 series is available with five different lid options to suit a wide range of mountings. Used extensively in pumps, vending machines and animated displays, this unit is the perfect solution for any application that requires a quiet, robust and reliable gearbox.



DC T6 Series

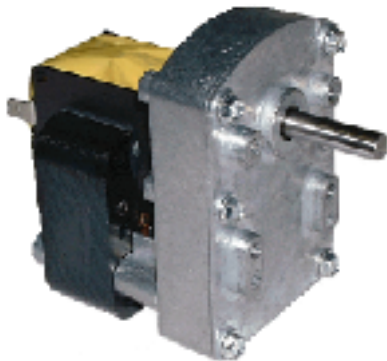

UB T6 Series

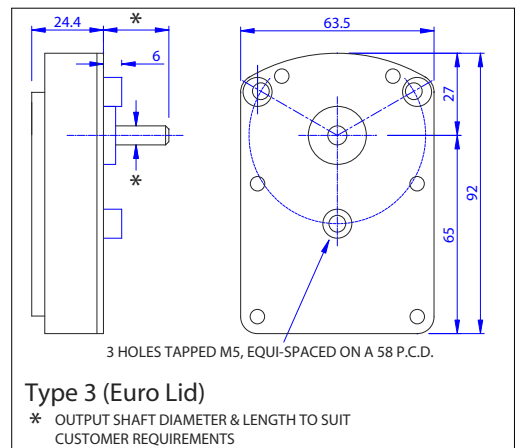
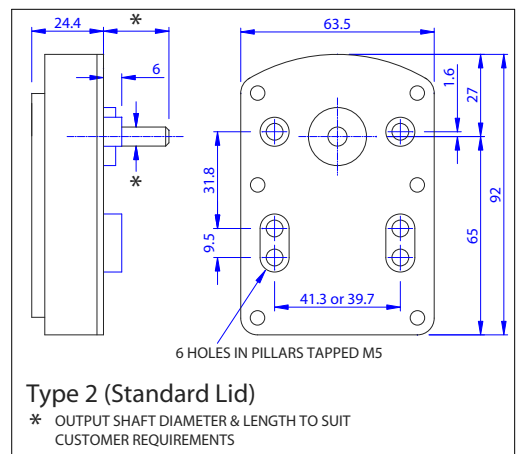
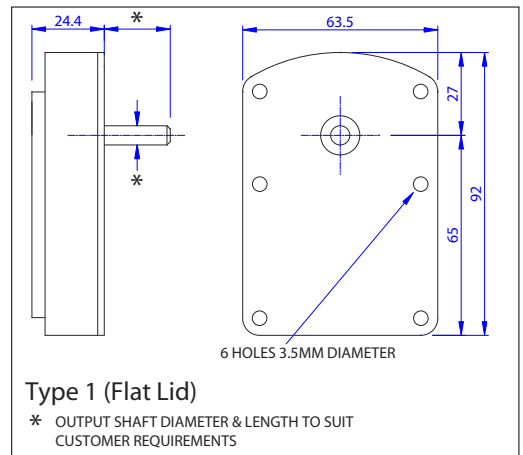

RS

DC Permanent magnet field motors
(See RS motor data sheet)

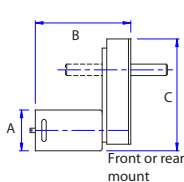

UBD80	RS-550	36	57	96
UBD81	RS-555	36	57	96

Refer to relevant motor data sheets for full motor specifications
Note: Measurement B is from mounting holes.

SC9

AC Single phase shaded pole motors
(See SC9 motor data sheet)

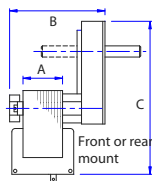

Cat No.	Motor	A	B	C
UBSS60	SC9-50	13	65	140
UBSS61	SC9-75	19	71	140
UBSS62	SC9-100	25	77	140
UBSS63	SC9-125	32	84	140
UBSS64	SC9-150	38	90	140

SC9

AC Single phase shaded pole motors
(See SC9 motor data sheet)

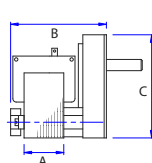

UBLS65	SC9-50	13	65	92
UBLS66	SC9-75	19	71	92
UBLS67	SC9-100	25	77	92
UBLS68	SC9-125	32	84	92
UBLS69	SC9-150	38	90	92