

Servomotori ES4004A – 10D30A1 Series



General

Motor Model	ES4004A-10D30A1
Rated Power W	100
Rated Voltage V	220
Rated Current A	1.1
Rated Speed Rpm	3000
Rated Torque N.m	0.32
Max Torque N.m	0.96
Voltage Constant V/1000 rpm	19
Torque Coefficient N.m/A	0.265
Rotor Inertia Kg.m ²	0.06x10 ⁻⁴
Line-line resistance Ω	11
Line-line inductance	8.5

Servomotori ES4004A – 10D30A1 Series

Mechanical time-constant Ms	2
Weight Kg	0.5
Encoder line number PPR	17 bit
Insulation class	F
Safe class	IP 65
The operating	-20°C~+50°C

Motor wiring

Motor winding plug	Winding lead wire	U red	V white	W black	PE yellow/green
	Plug serial number	1	2	3	4

Plug winding plug		1	2	3	4	5	6
Signal lead wire	17 Photoelectric encoder socket	NC	SD+	SD-	Vcc	GND	Shielded

Installation precaution

1. When installing and removing the position to the end of the motor shaft, please don't force the shaft to prevent the encoder.
2. Try to prevent the shaft seat vibration, to prevent bearing damage.

Servomotori ES4004A – 10D30A1 Series

Installation Dimensions

- 40 without brake:

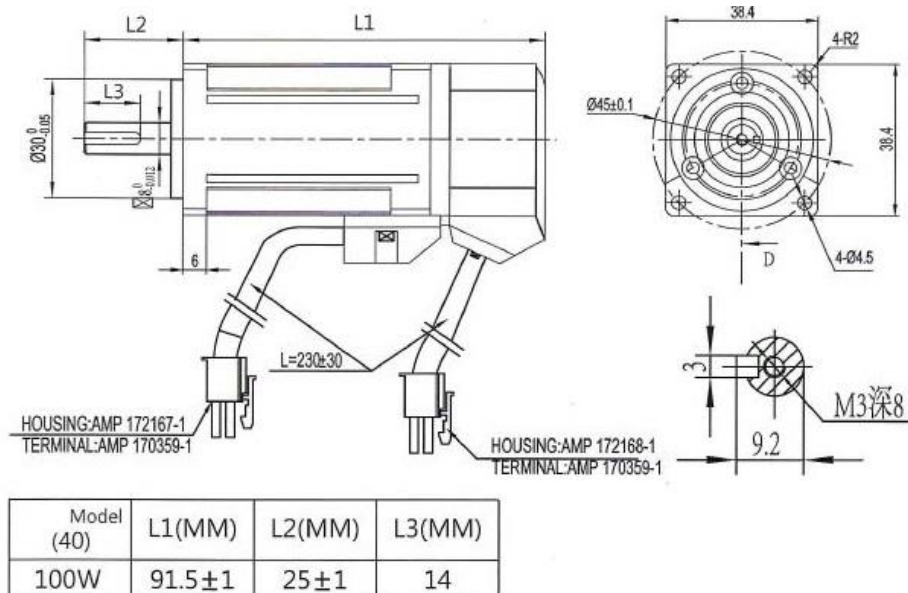

- 40 with brake:

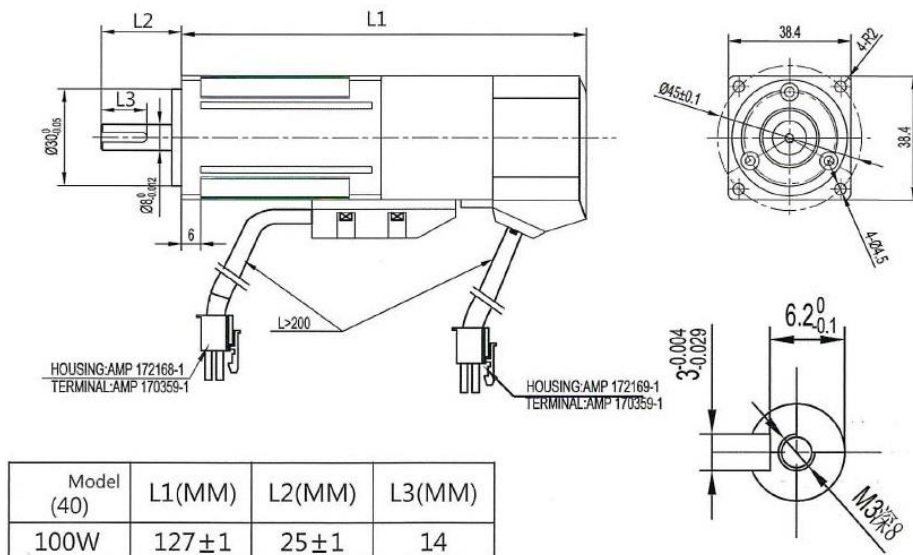

Softing Italia Srl

Via M. Kolbe 6,
Cesano Boscone (MI)
info.it@softing.com
www.softingitalia.it/motors